

SG - Spark Gaps



Spark Gap Surge Diverter

Use Spark Gap Surge Diverters for point of entry protection at main switchboards where direct strike protection is required.

Multilayer Carbon Disc Technology

Carbon disk spark gaps are a robust and proven technology designed to handle long duration surges. The low resistance design minimises the energy dissipation within the device.

High Energy Impulse Protection

Two models are available with either 50 kA or 110 kA of impulse current handling per phase for even the most extreme lightning environments.

Sealed Enclosure

The Novaris spark gap diverters are a sealed unit and do not exhaust hot ionised gas into the switchboard.

Note: It is highly recommended to install MOV based protection at the first layer distribution when using spark gaps for primary protection due to the arc establishment time of spark gap technology.

Diagram / Installation

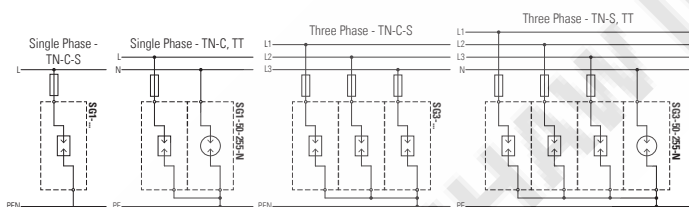

Ordering Information

	Main Switchboard Network Type	
	TN-C-S (MEN)	TN-S and TT
Medium Exposure		
Single Phase	SG1-50-255	SG1-50-255-N
Three Phase	SG3-50-255	SG3-50-255-N
High Exposure		
Single Phase	SG1-110-275	-
Three Phase	SG3-110-275	-

Dimensions

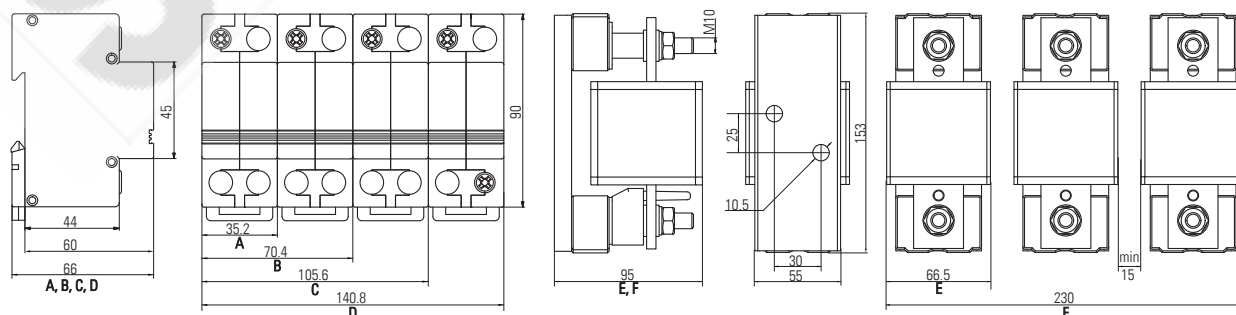

Product Specifications

Model		SG1-50-255	SG1-50-255-N	SG3-50-255	SG3-50-255-N	SG1-110-275	SG3-110-275
Electrical Specifications							
Connection type		Shunt	Shunt	Shunt	Shunt	Shunt	Shunt
Modes of protection		L-N	L-N, N-PE	L-N	L-N, N-PE	L-N	L-N
Phases		1	1	3	3	1	3
Nominal voltage	U_0	230 VAC	230 VAC	230 VAC	230 VAC	230 VAC	230 VAC
Short circuit withstand level	I_{SCCR}	25 kA	25 kA	25 kA	25 kA	50 kA	50 kA
Maximum backup fuse (gL/gG)		500 A	500 A	500 A	500 A	500 A	500 A
L-N							
Maximum continuous voltage	U_c	255 VAC	255 VAC	255 VAC	255 VAC	275 VAC	275 VAC
Maximum discharge current (8/20 μ s)	I_{max}	120 kA	120 kA	120 kA	120 kA	240 kA	240 kA
Lightning impulse current (10/350 μ s)	I_{imp}	50 kA	50 kA	50 kA	50 kA	110 kA	110 kA
Nominal discharge current (8/20 μ s)	I_n	50 kA	50 kA	50 kA	50 kA	50 kA	50 kA
Voltage protection level @ 3 kA 8/20 μ s	U_p	< 2000 V	< 2000 V	< 2000 V	< 2000 V	< 3200 V	< 3200 V
Voltage protection level @ I_{imp}	U_p	< 2000 V	< 2000 V	< 2000 V	< 2000 V	< 2500 V	< 2500 V
Response time	t_A	< 100 ns	< 100 ns	< 100 ns	< 100 ns	< 100 ns	< 100 ns
Temporary overvoltage (TOV)	U_T	334 V / 5 s	334 V / 5 s	334 V / 5 s	334 V / 5 s	334 V / 5 s	334 V / 5 s
N-PE							
Maximum continuous voltage	U_c	–	255 VAC	–	255 VAC	–	–
Maximum discharge current (8/20 μ s)	I_{max}	–	150 kA	–	150 kA	–	–
Lightning impulse current (10/350 μ s)	I_{imp}	–	100 kA	–	100 kA	–	–
Nominal discharge current (8/20 μ s)	I_n	–	75 kA	–	75 kA	–	–
Voltage protection level @ 1 kV/ μ s	U_p	–	< 800 V	–	< 800 V	–	–
Voltage protection level @ I_{imp}	U_p	–	< 1300 V	–	< 1300 V	–	–
Response time	t_A	–	< 100 ns	–	< 100 ns	–	–
Temporary overvoltage (TOV)	U_T	–	1200 V / 0.2 s	–	1200 V / 0.2 s	–	–
Follow current interrupt rating	I_f	–	100 A	–	100 A	–	–
Earth leakage current		–	< 10 μ A	–	< 10 μ A	–	–
Mechanical Specifications							
Operating temperature		-40 to +70 °C	-40 to +70 °C	-40 to +70 °C	-40 to +70 °C	-40 to +70 °C	-40 to +70 °C
Humidity Range		5 to 95% non-condensing					
Terminal capacity – power		35 mm ²	35 mm ²	35 mm ²	35 mm ²	Lug \varnothing 10	Lug \varnothing 10
Terminal screw torque – power		2.5 Nm	2.5 Nm	2.5 Nm	2.5 Nm	–	–
Environmental / Location		IP 20	IP 20	IP 20	IP 20	IP 00	IP 00
Dimensional Drawing		A	B	C	D	E	F
Device width		35.2 mm	70.4 mm	105.6 mm	140.8 mm	66.5 mm	201 mm
Mounting		TS35 DIN rail	TS35 DIN rail	TS35 DIN rail	TS35 DIN rail	Panel mount	Panel mount
Enclosure / Colour		Flame retardant Polyamide 6 / black				Metal & Flame retardant Polyam. 6 / black	
Standards							
IEC 61643-11:2011		SPD connected to low-voltage power systems - Type 1+2					
AS/NZS 1768:2007		A.C. power system SPD - Cat C, B					
UL 1449 3 rd edition		Low voltage SPD - Type 2 (distribution), Type 3 (< 10 m from device)					
IEEE 62.41.2:2002		Low voltage SPD - Cat B (indoor), Cat C (< 10 m from device)					
Shipping							
Weight		230 g	460 g	690 g	920 g	1000 g	3000 g
Customs Tariff		85354010	85354010	85354010	85354010	85354010	85354010

