

Applications:

Ark•Gard® ENR-GFCI kits are used:

- To interrupt a circuit when ground fault is detected on equipment which may be handled by personnel in hazardous locations
- With portable electrical equipment, such as tools, lighting systems, compressors and similar devices for personnel protection
- In branch circuits of 15 to 20 amperes at 125 VAC

In applications such as:

- Refineries
- Chemical plants
- LNG facilities
- Wastewater treatment facilities
- Drilling and exploration

Features:

- Allows for a single part number to be specified, ordered and delivered on-site, significantly reducing the cost of order processing, material handling and misplacement of materials
- Components meet all UL and CSA requirements for ground fault protection in hazardous locations
- Includes all of the value added features of the ENR receptacle
- The GFCI protects personnel against possible injury due to unwanted ground faults; meets requirements for personnel protection as defined in the National Electrical Code
- Field installation is accomplished with standard tools

Certifications and compliances:

NEC/CEC listed components:

- Class I, Divisions 1 & 2, Groups B^A, C, D
- Class II, Divisions 1 & 2, Groups F, G
- Class III

ANSI/UL standards:

- UL943, UL1203

NEMA/EEMAC:

- NEMA/EEMAC 3, 7CD, 9FG, 12

CSA standard:

- C22.2 Nos. 30, 144

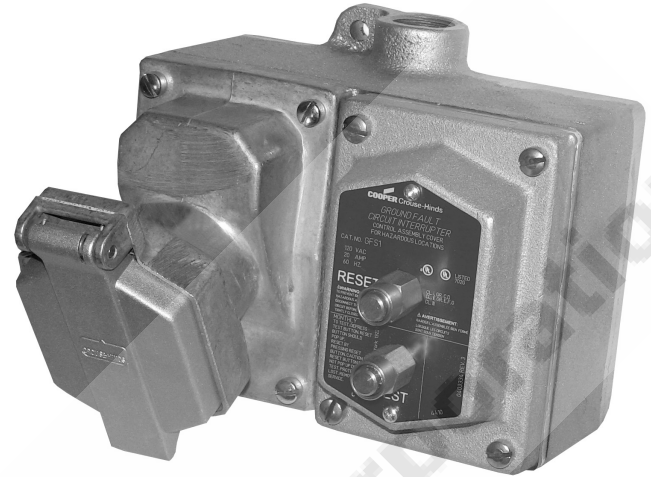

Standard materials:

ENR receptacle:

- Receptacle housing, spring door and plug body – die cast copper-free aluminum
- Interiors – receptacle: Krydon fiberglass-reinforced polyester
- Contacts – receptacle blade: brass; receptacle switch: silver
- Receptacle cover hinge pin and spring – stainless steel
- Receptacle gasket – neoprene
- Back box – Feraloy iron alloy

GFS ground fault circuit interrupter:

- Cover – sand cast copper-free aluminum
- Sealing well – die cast copper-free aluminum
- Pushbuttons and guards – stainless steel
- Shaft seals – neoprene
- Interior – body: polycarbonate; contacts: brass

Standard finishes:

ENR receptacle:

- Feraloy iron alloy – electrogalvanized and aluminum acrylic paint
- Copper-free aluminum – aluminum acrylic paint
- Brass – natural

GFS ground fault circuit interrupter:

- Copper-free aluminum – aluminum lacquer
- Stainless steel – natural
- Polycarbonate – natural (ivory)
- Brass – natural

Electrical ratings:

- 15 and 20 amperes, 125 VAC
- 5 milliampere trip setting
- Class A per ANSI/UL943

^A Tested and self-certified by Eaton's Crouse-Hinds Division for Group B.

Ark•Gard ENR-GFCI kits

Cl. I, Div. 1 & 2, Groups B[ⓔ], C, D
 Cl. II, Div. 1 & 2, Groups F, G
 Cl. III
 NEMA 3, 7B[ⓔ]CD, 9FG, 12

Explosionproof
 Dust-ignitionproof

2P

Ordering information:

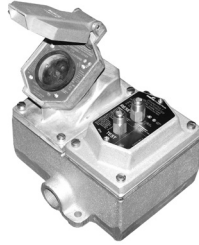

Rating	Description	Hub size	Cat. #	NEMA configuration	Cat. # Plug	NEMA configuration
15A, 125V	Dead end	1/2"	ENR12151 GFI		ENP5151	
		3/4"	ENR22151 GFI			
	Through feed	1"	ENR32151 GFI			
		1/2"	ENRC12151 GFI			
		3/4"	ENRC22151 GFI			
		1"	ENRC32151 GFI			
20A, 125V	Dead end	1/2"	ENR12201 GFI		ENP5201	
		3/4"	ENR22201 GFI			
	Through feed	1"	ENR32201 GFI			
		1/2"	ENRC12201 GFI			
		3/4"	ENRC22201 GFI			
		1"	ENRC32201 GFI			

Dimensions (in inches):

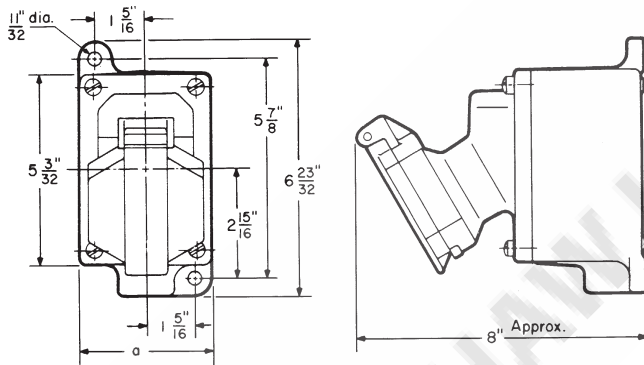

[ⓔ] Tested and self-certified by Eaton's Crouse-Hinds Division for Group B.